



VEGA Overview



VEGA50FT



Contents

- ◆ Access

- DB2 from CA-IDMS
- CICS from CA-IDMS
- ODBC from CA-IDMS and BATCH
- CA-IDMS and BATCH from Windows
- CA-IDMS from Internet
- CA-IDMS from Java



Contents

- ◆ Use
 - TCP/IP in CA-IDMS applications
 - MQSeries in CA-IDMS applications
- ◆ System requirements



Options to access DB2

- ◆ VEGA supports two options to access DB2
 - Native 3GL access
 - VEGA Client/Server access to DB2
 - this is VEGA proprietary API

DB2 Native 3GL

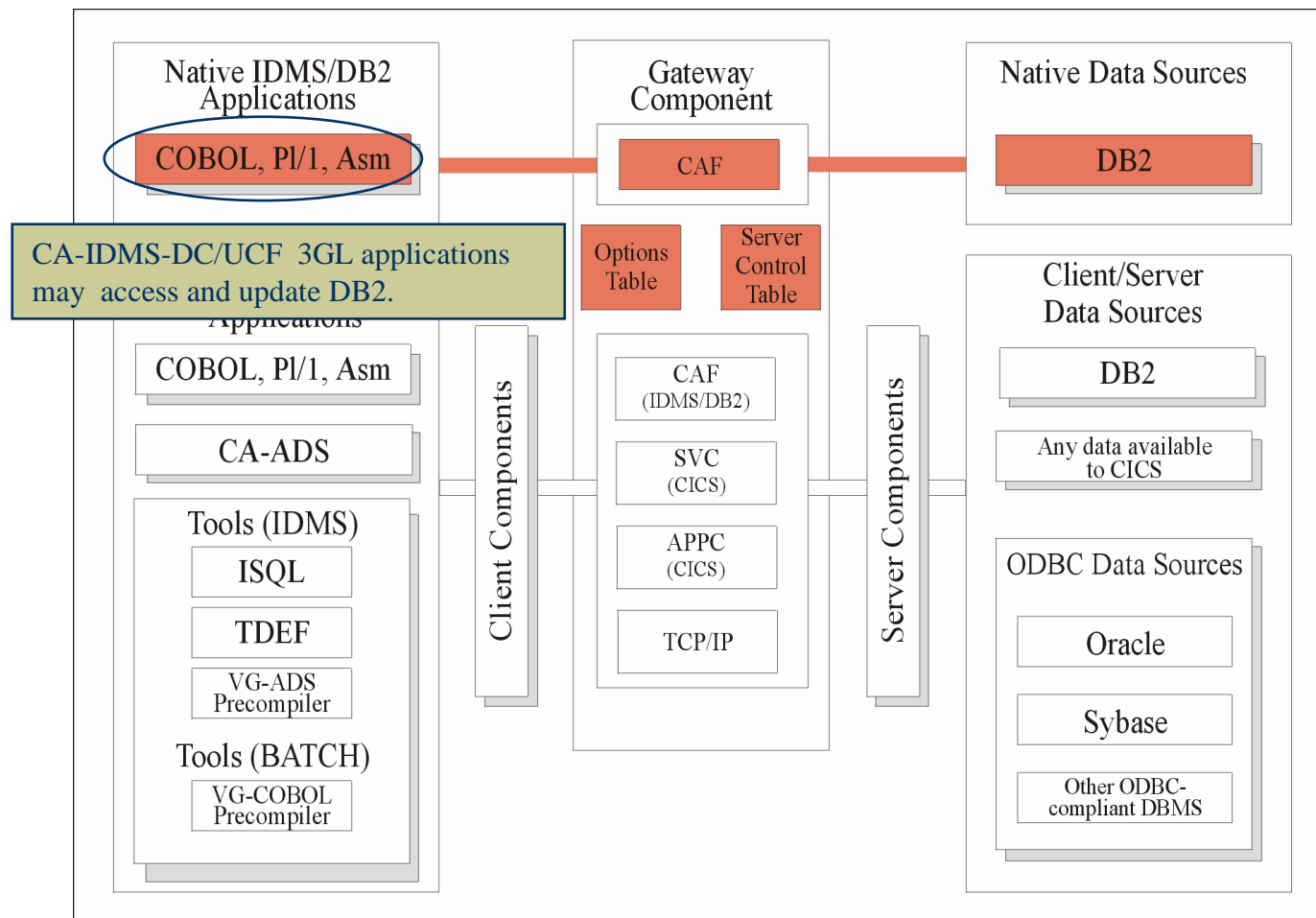

DB2 Native 3GL

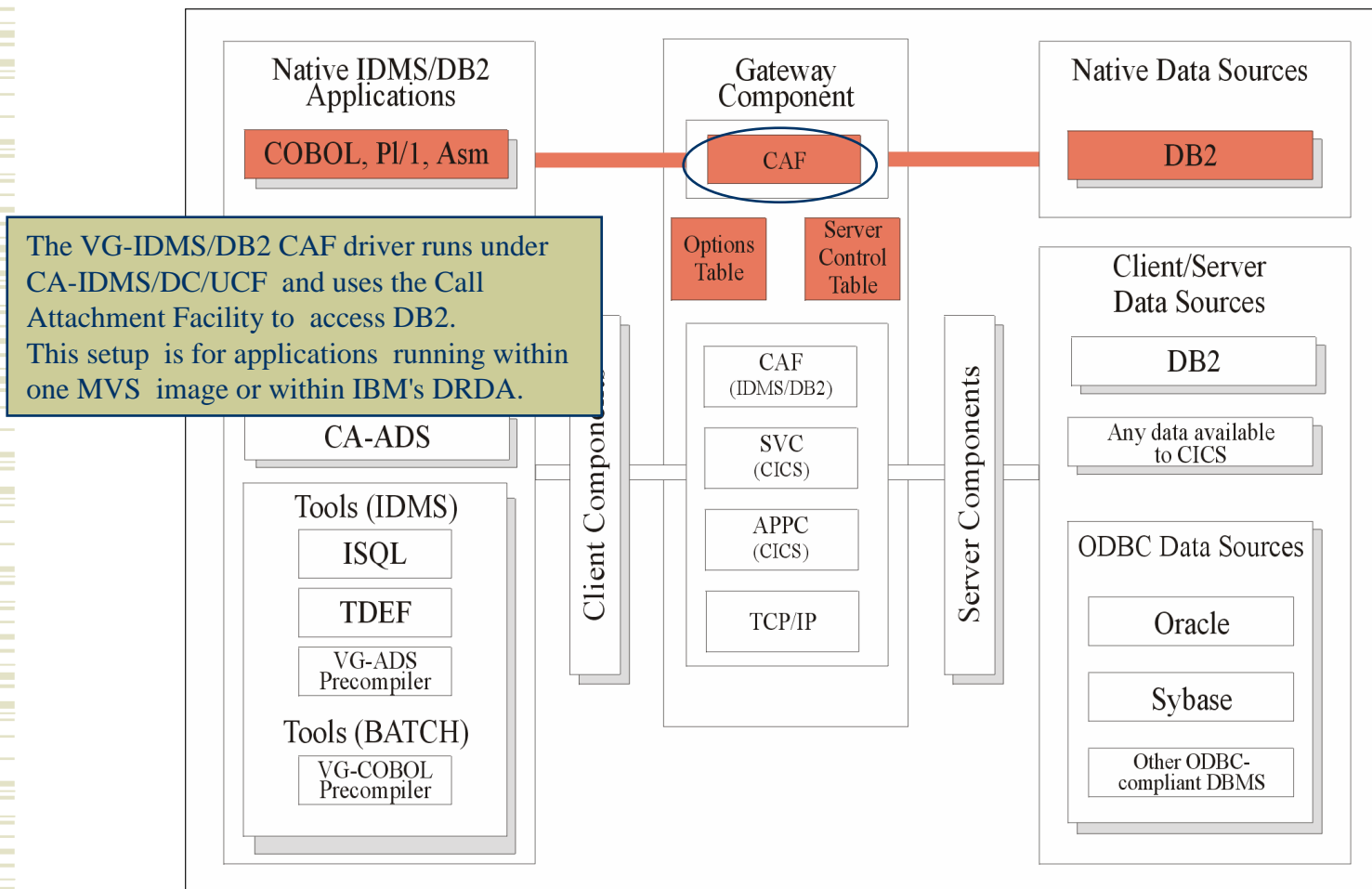

DB2 Native 3GL

- ◆ Embed DB2 SQL into CA-IDMS-DC/UCF 3GL programs
 - e.g. COBOL or PL/1
- ◆ Precompile in this order
 - DB2
 - CA-IDMS
- ◆ Compile
- ◆ Link edit
 - Replace DSNHLI with MDB2HLI

DB2 Native 3GL

- ◆ MDB2HLI routes DB2 calls to VEGA Call Attachment Facility (CAF) driver
- ◆ Cross-address space communication based on MVS subtasks
 - no IDMS region waits
- ◆ Consistent Update Method
 - synchronizes DB2 and CA-IDMS updates
- ◆ Restriction
 - in practice it's not possible to use DB2 and CA-IDMS SQL in the same program (DML is OK)

CAF run-time environment

- ◆ CAF Logical Terminal Area (CAF LTE)
 - control blocks to manage the DB2 Connection and application program threads
 - created during CA-IDMS-DC/UCF startup
 - defined in VG-IDMS Gateway Server Control Table (SCT)
 - stored in CA-IDMS-DC/UCF Storage Pool
 - NOT related to CA-IDMS LTEs

CICS Client/Server

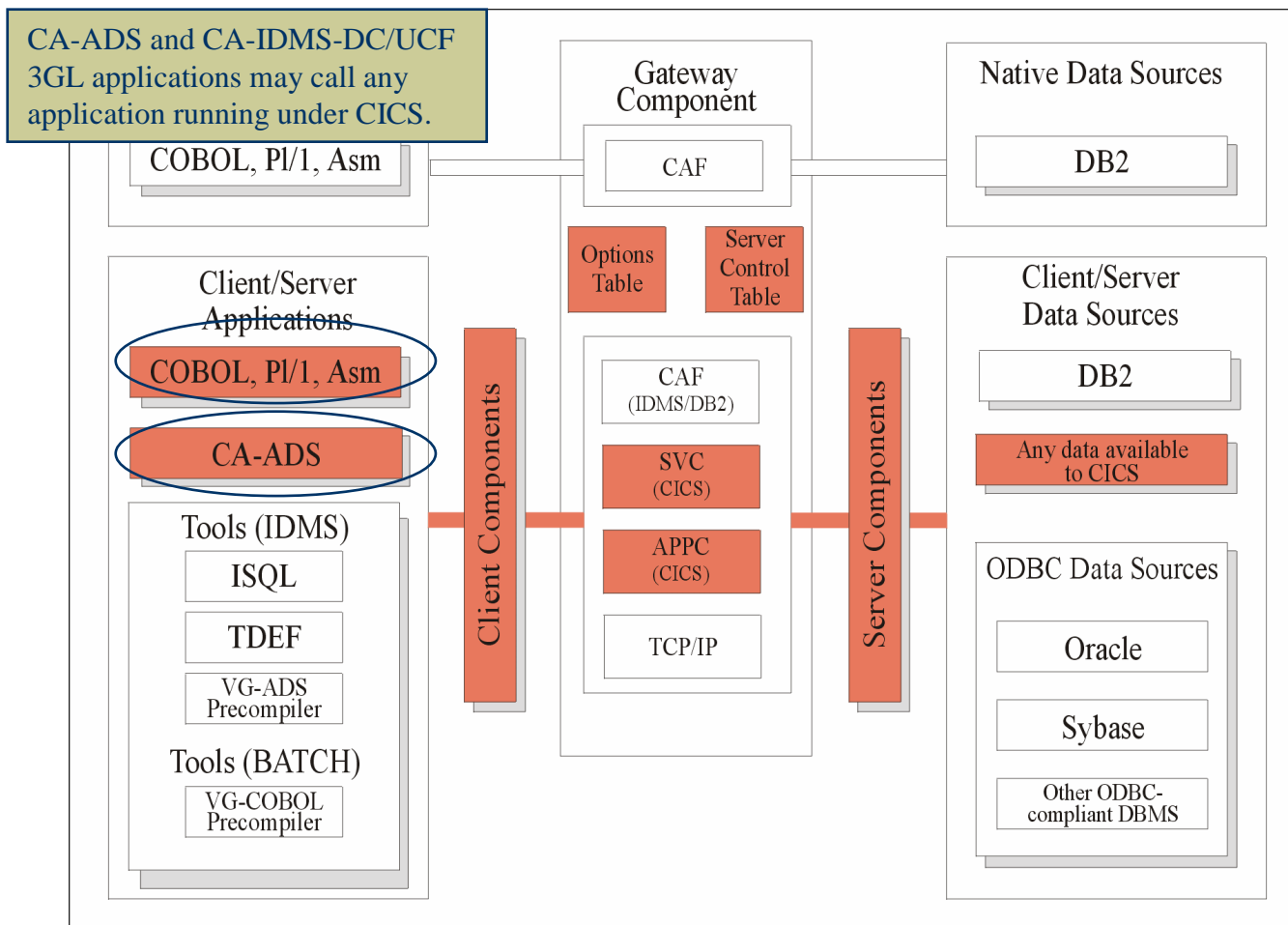

CICS Client/Server

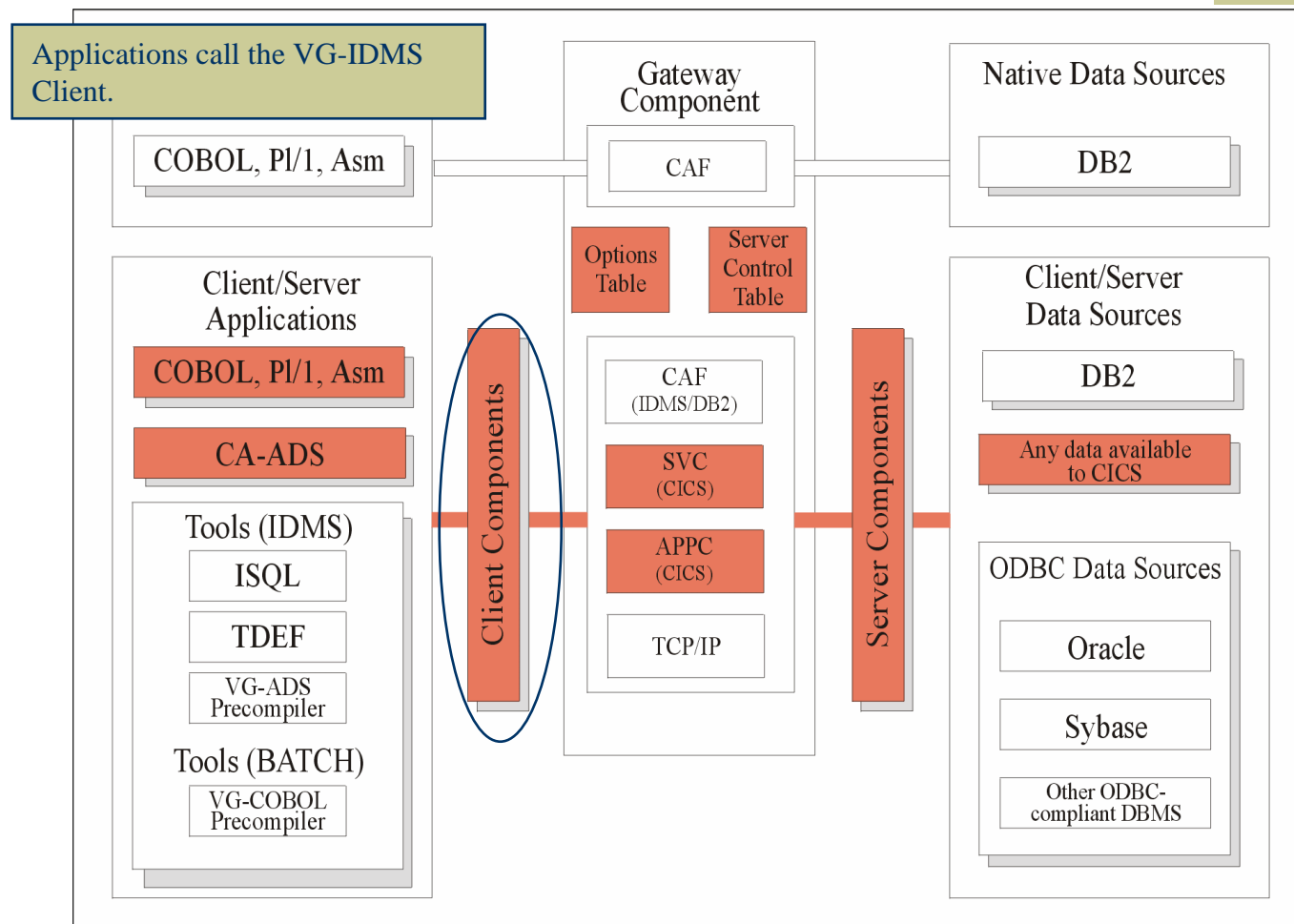

CICS Client/Server

The VG-CICS Server communicates with the VEGA Client using either Supervisor Call (SVC) or APPC (LU6.2).

SVC is for applications running within one MVS image.

APPC can also access remote CICS systems.

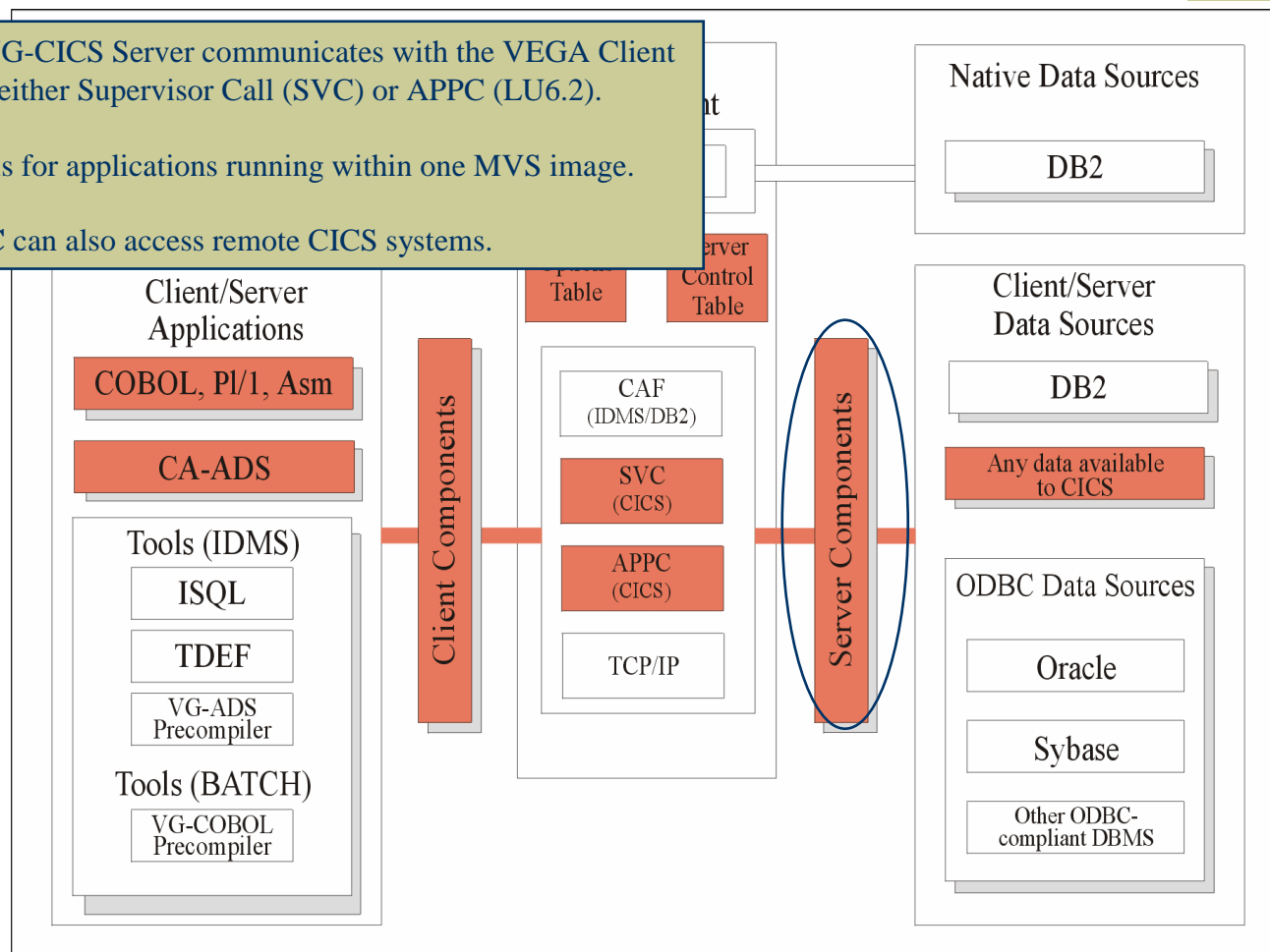

CICS Client/Server

- ◆ CA-ADS and CA-IDMS/DC/UCF applications can call any application running under CICS using VEGA API
- ◆ VG-IDMS Client talks to VG-CICS Server
- ◆ Client applications can pass data to CICS applications
- ◆ Server applications can return data

DB2 Client/Server

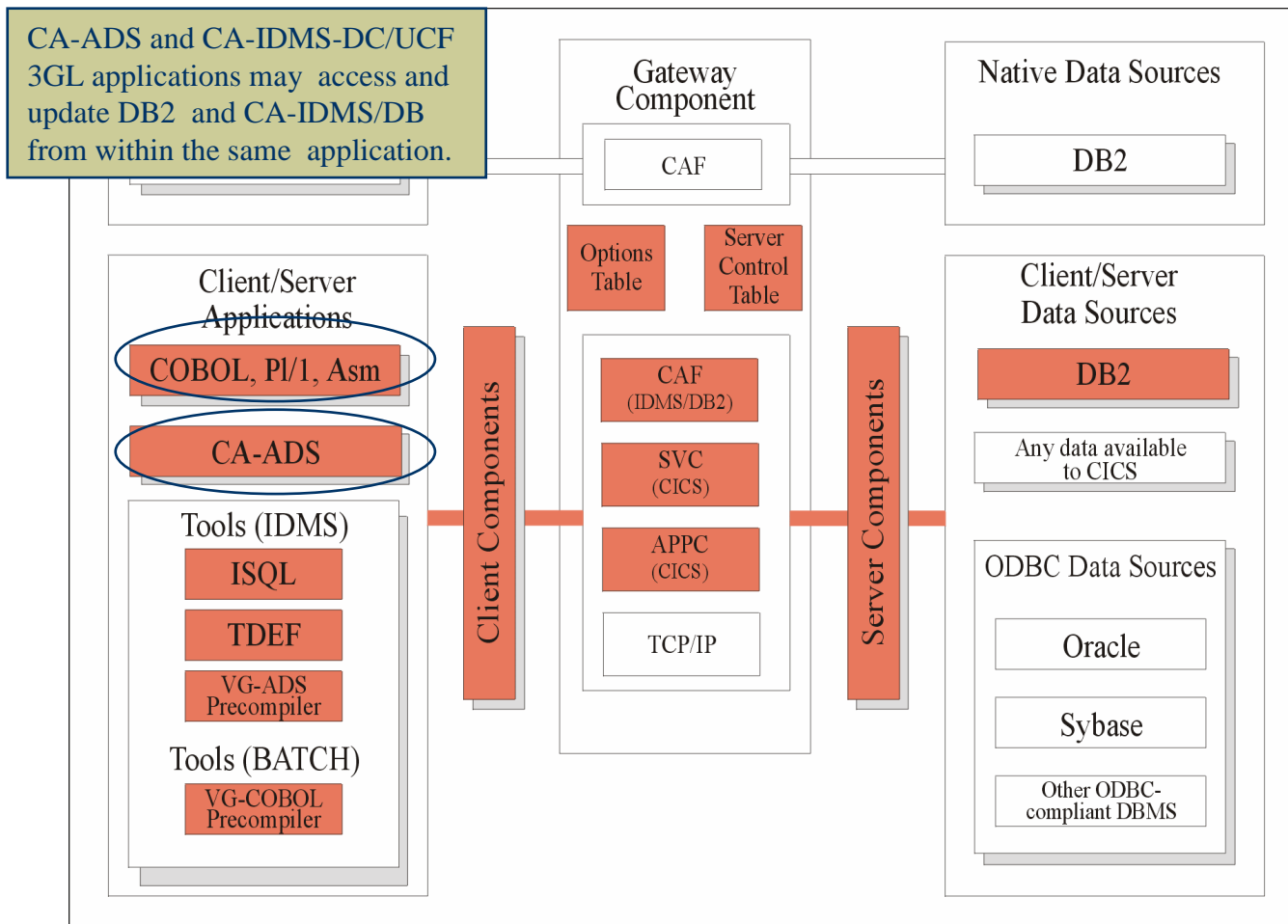

DB2 Client/Server

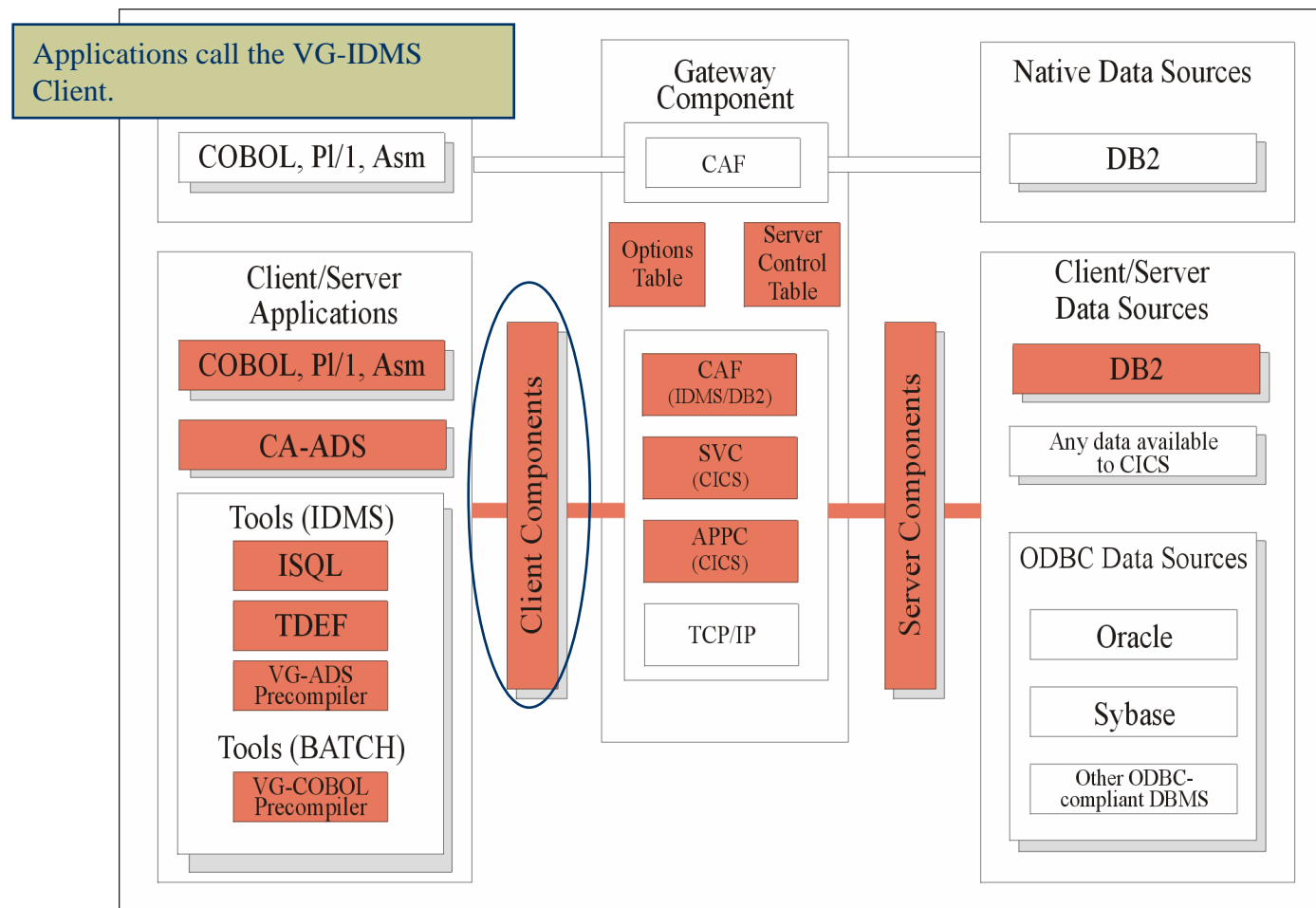

DB2 Client/Server

The VG-IDMS/DB2 Server runs under CA-IDMS-DC/UCF and uses the Call Attachment Facility to access DB2.

This setup is for applications running within one MVS image or within IBM's DRDA.

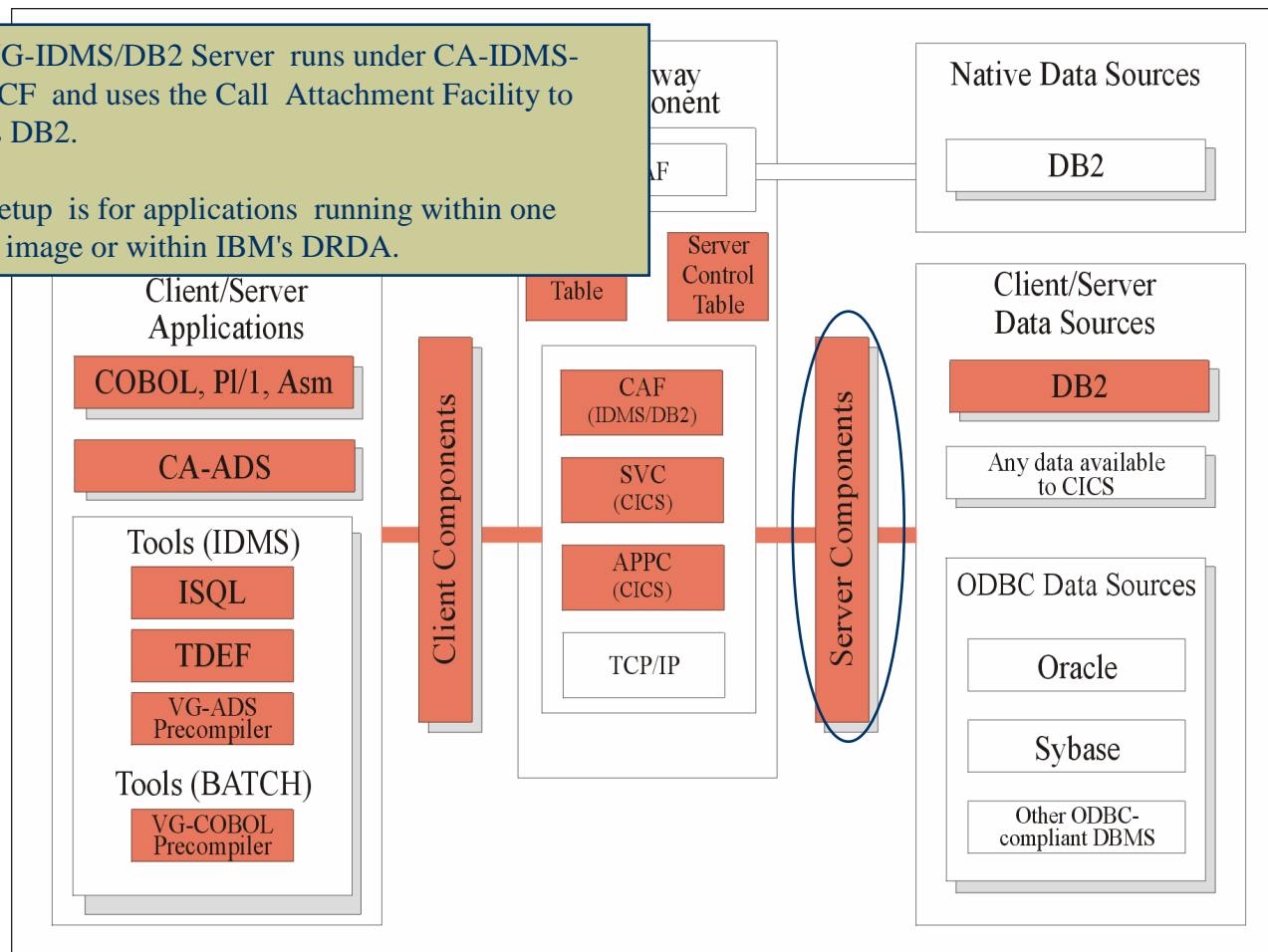

DB2 Client/Server

The VG-CICS Server communicates with the VEGA Client using either Supervisor Call (SVC) or APPC (LU6.2).

SVC is for applications running within one MVS image.

APPC can also access remote CICS systems.

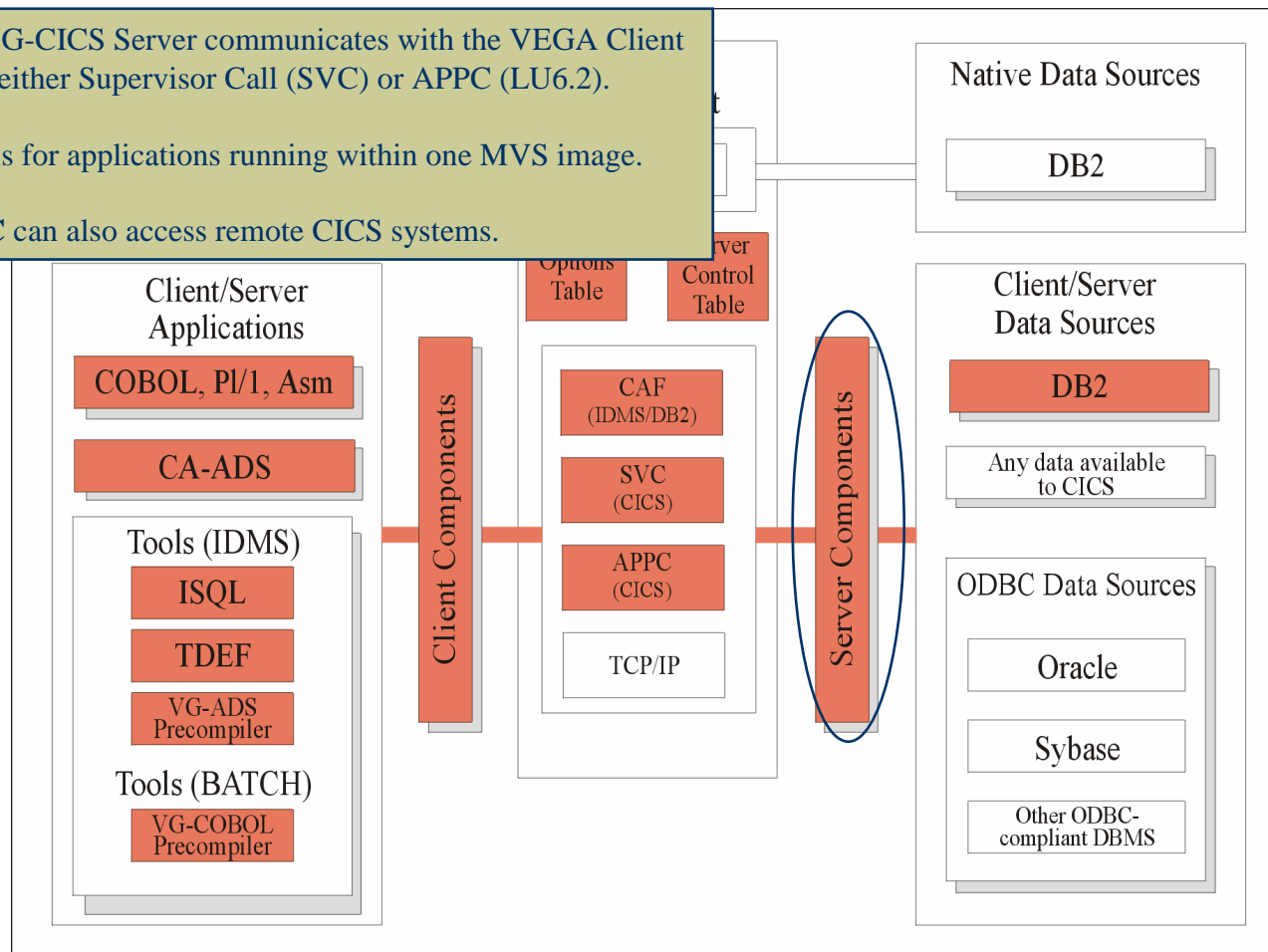



DB2 Client/Server

- ◆ Used by VEGA tools
 - ISQL
 - TDEF
 - VG-ADS Precompiler
- ◆ Used by Client/Server Applications generated with
 - VG-ADS Precompiler

ODBC Client/Server CA-IDMS

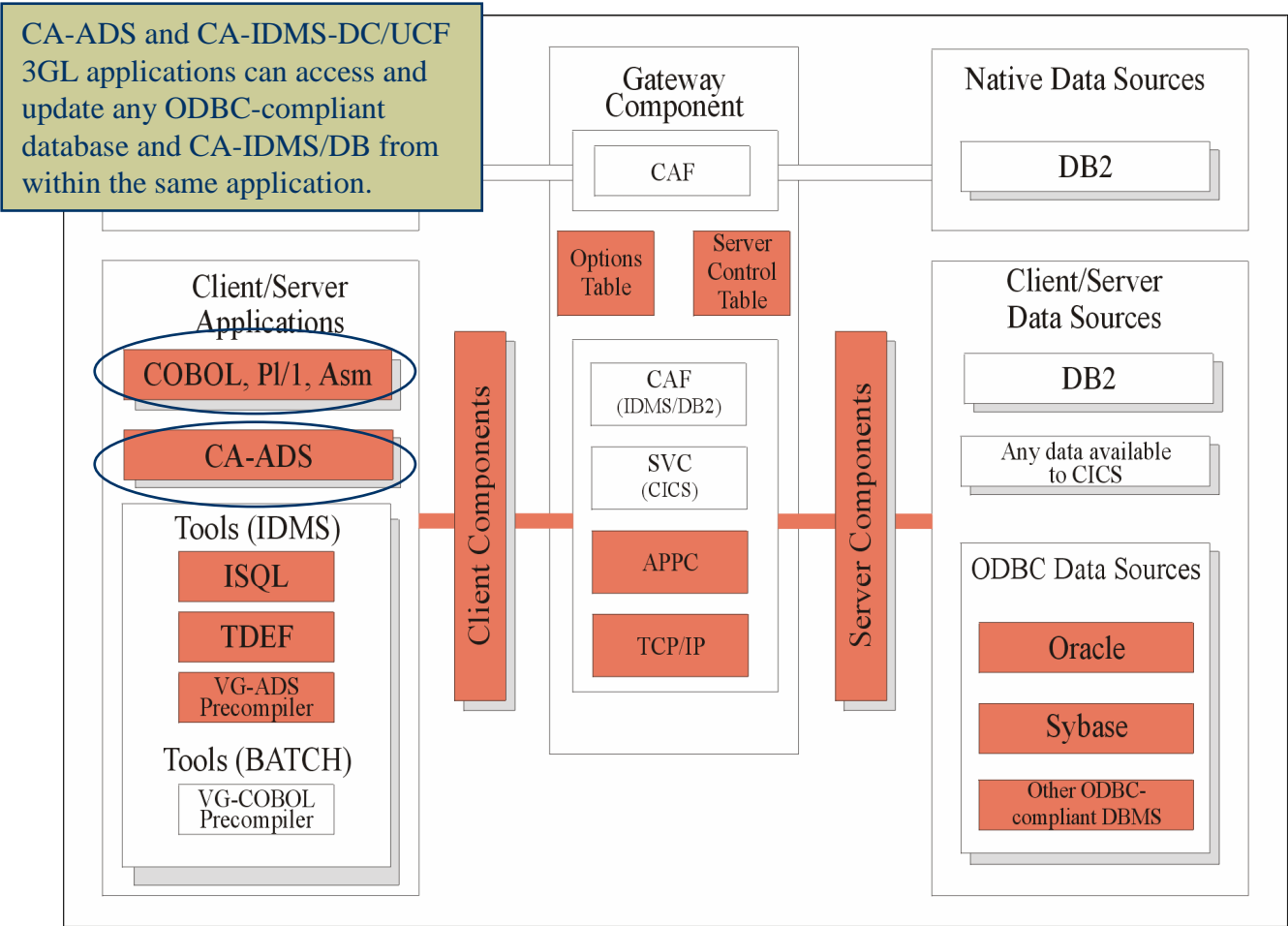

ODBC Client/Server CA-IDMS

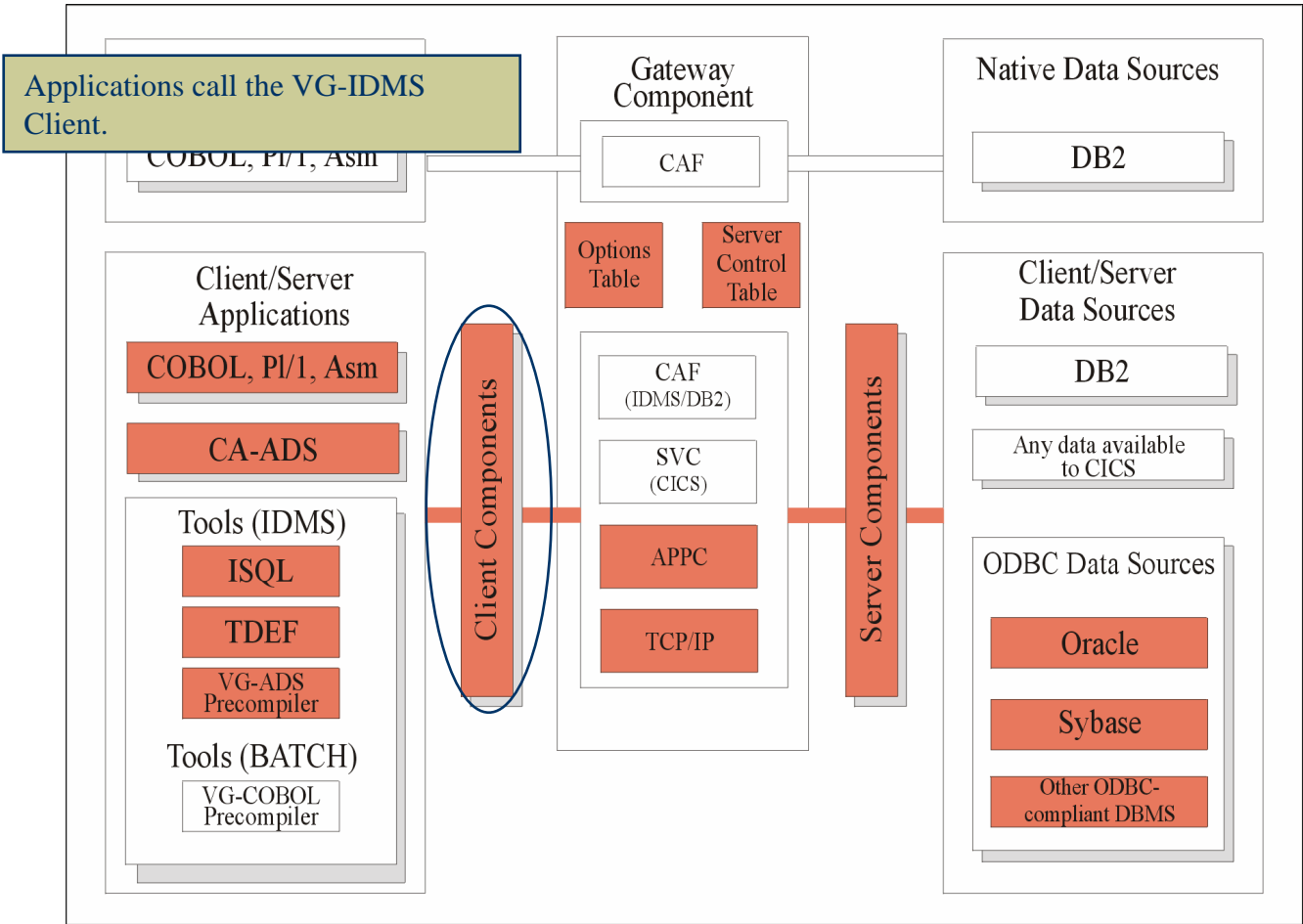

ODBC Client/Server CA-IDMS

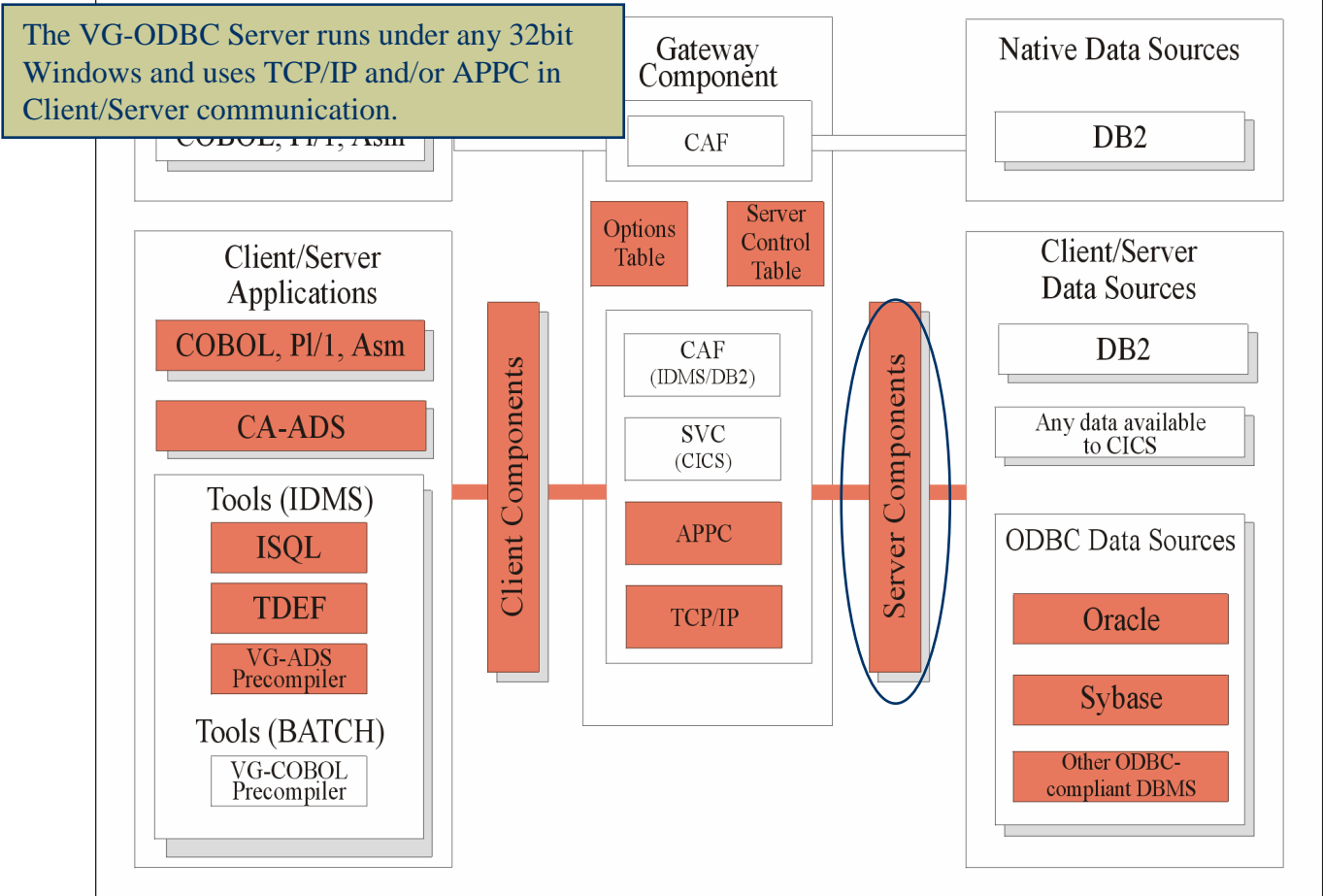

ODBC Client/Server Batch

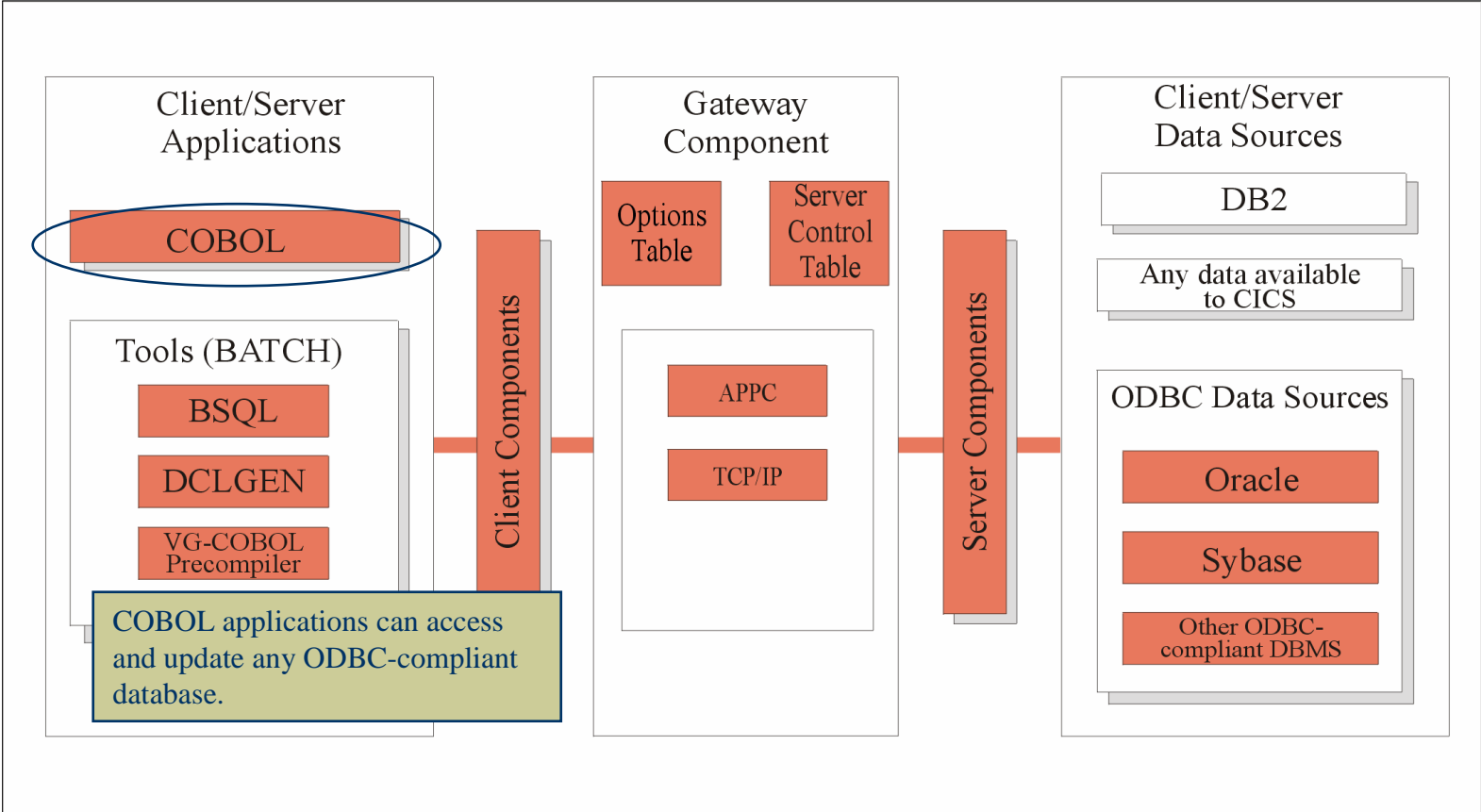

ODBC Client/Server Batch

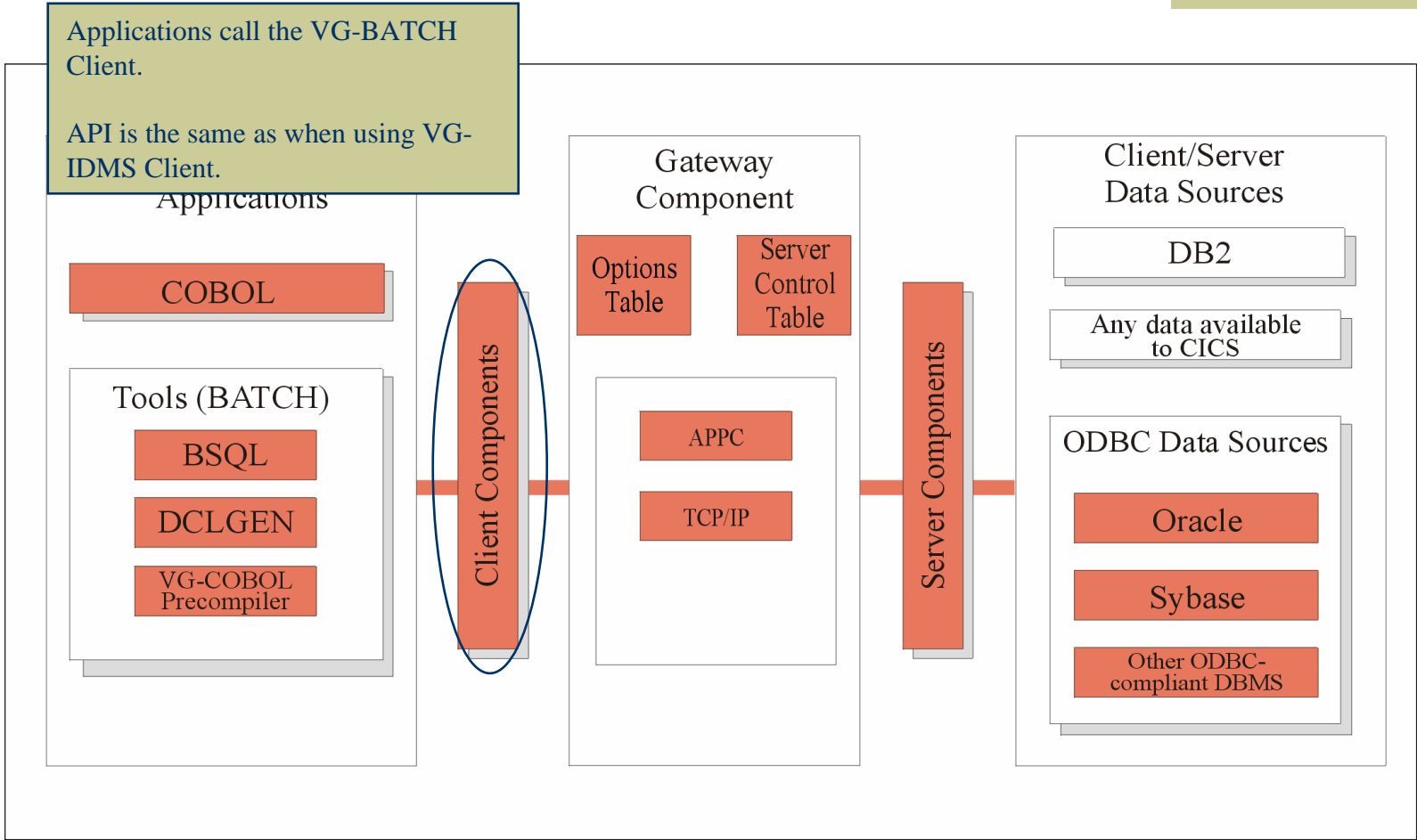

ODBC Client/Server Batch

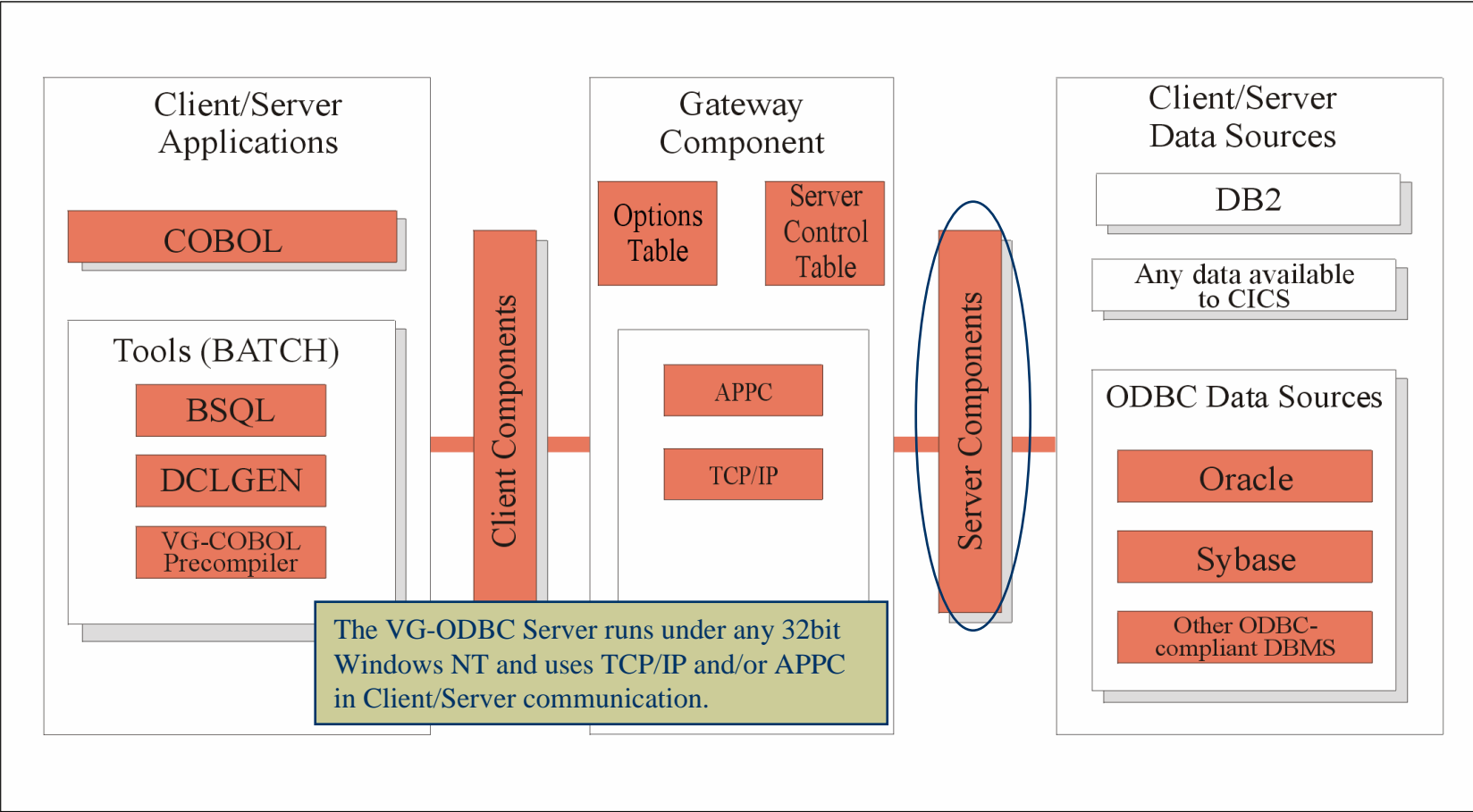

ODBC Client/Server

- ◆ Used by VEGA tools
 - ISQL/BSQL
 - TDEF/DCLGEN
 - VG-ADS Precompiler
 - VG-COBOL Precompiler
- ◆ Used by Client/Server Applications generated with
 - VG-ADS Precompiler
 - VG-COBOL Precompiler

ODBC Client/Server

- ◆ VG-ODBC Server does the following
 - Accepts requests from the Client
 - Converts VEGA API to ODBC API
 - Calls the DBMS specific ODBC driver to access the database
 - Retrieves output data, if any
 - Converts ODBC data to mainframe format
 - e.g. from Oracle DECIMAL to COMP-3

Windows Client/Server

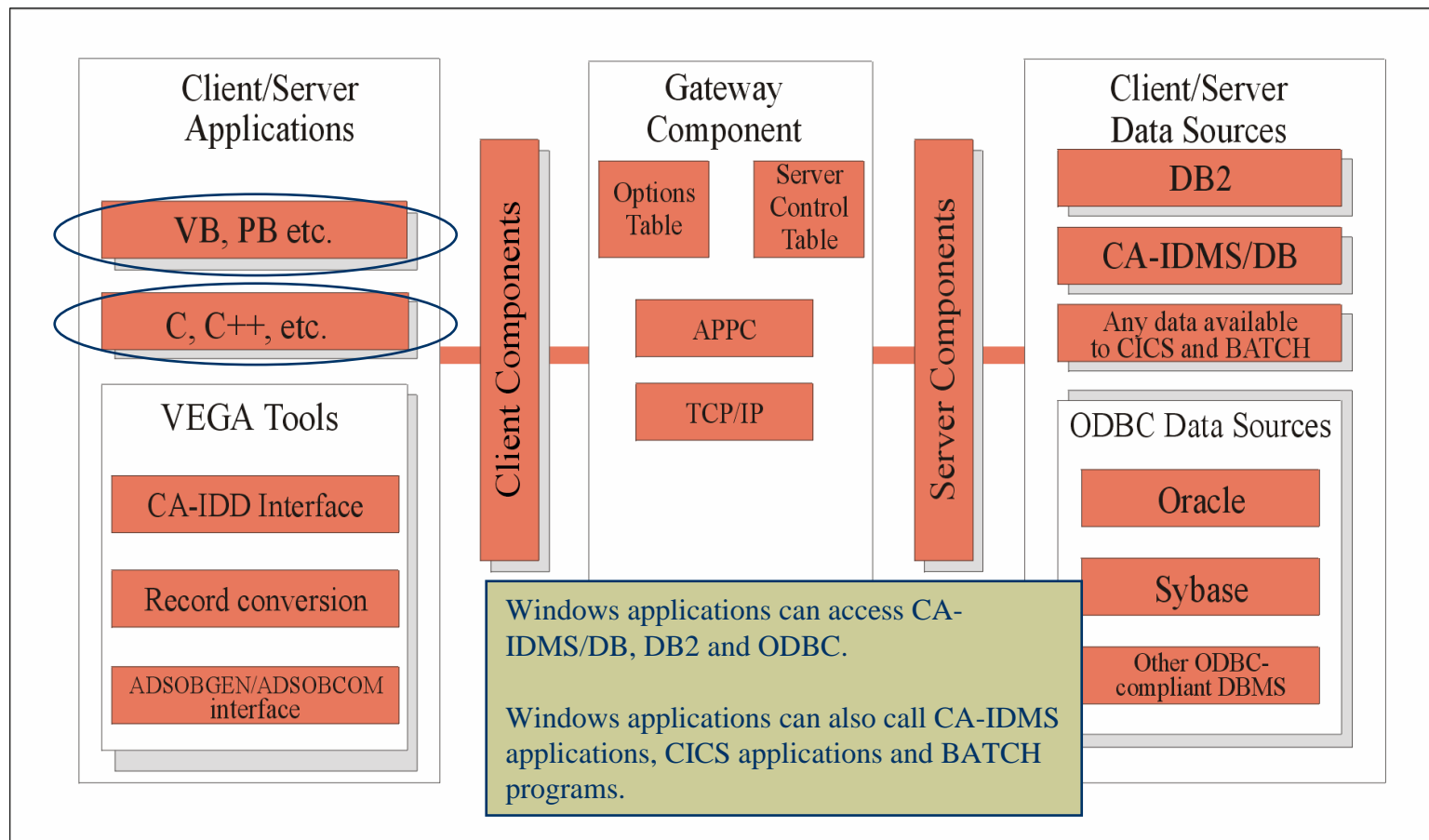

Windows Client/Server

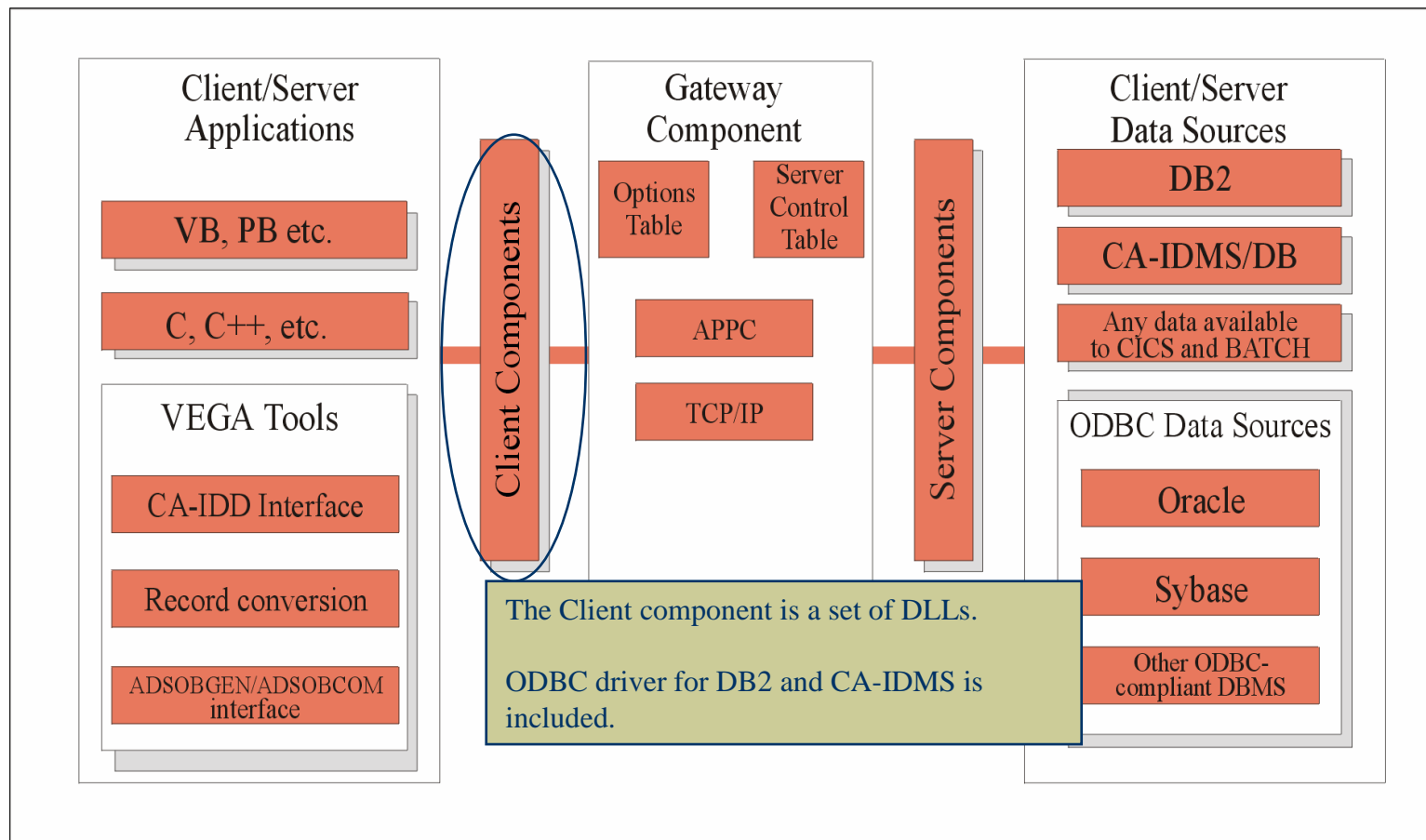

Windows Client/Server

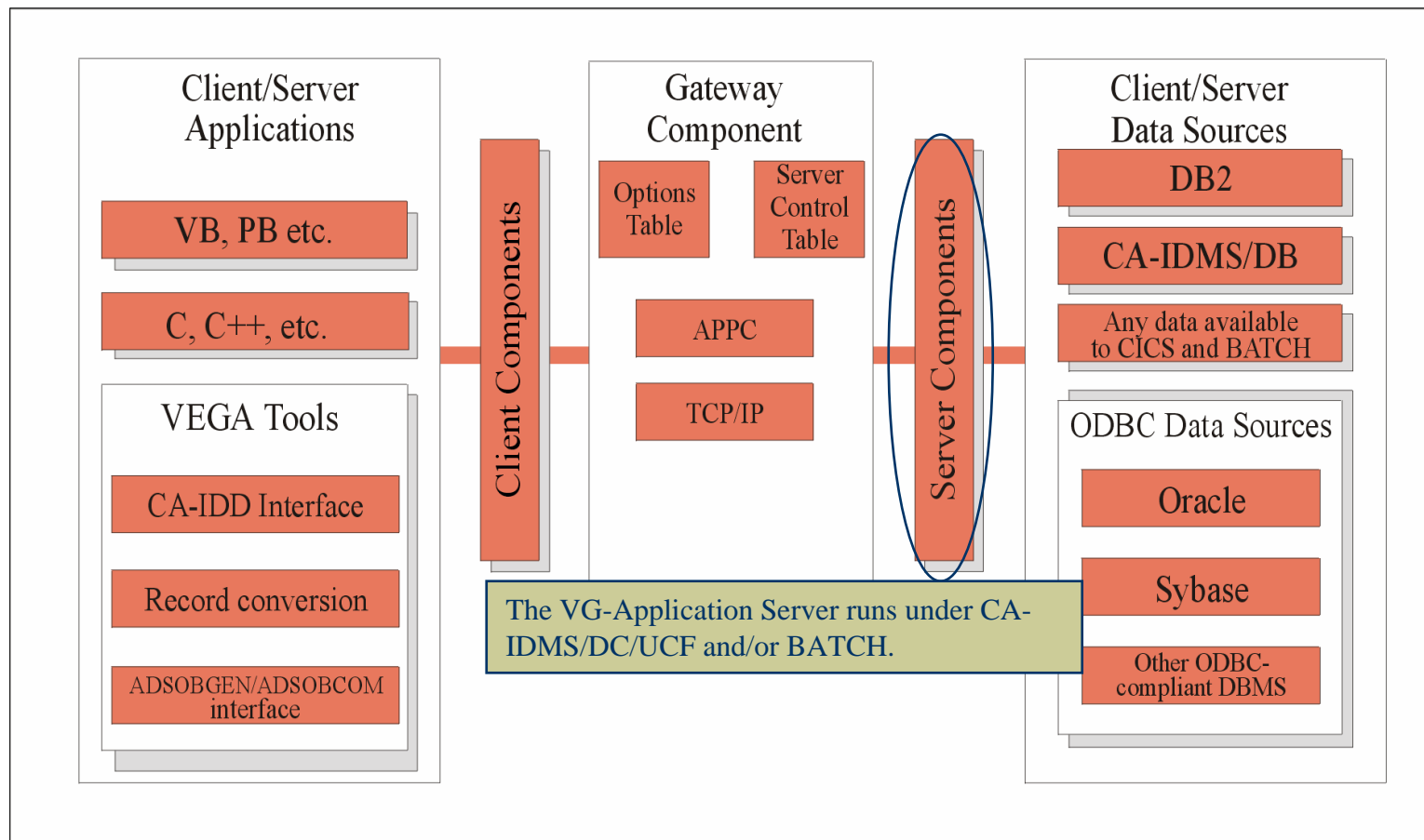

Windows Client/Server

- ◆ Any Windows application that can call DLLs can communicate with VG-Application Server
- ◆ Communication method (TCP/IP, APPC) is transparent to applications
- ◆ Client applications can access
 - CA-IDMS/DB via server applications
 - DB2 via server applications
 - DB2 and CA-IDMS/SQL with the included ODBC driver



Windows Client/Server

- ◆ Client applications can communicate with
 - CA-IDMS applications
 - CICS applications
 - BATCH applications

Access CA-IDMS from Internet

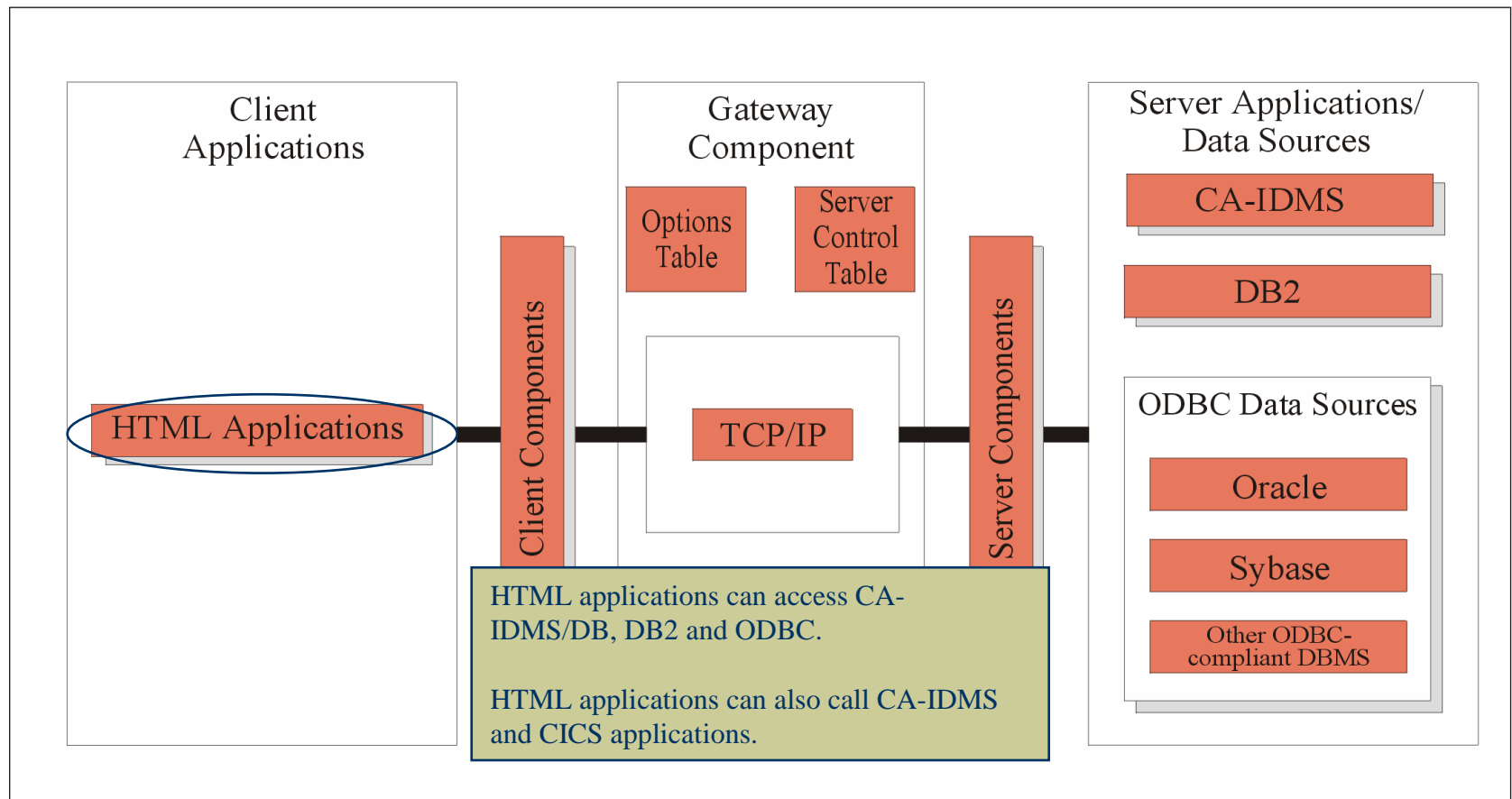

Access CA-IDMS from Internet

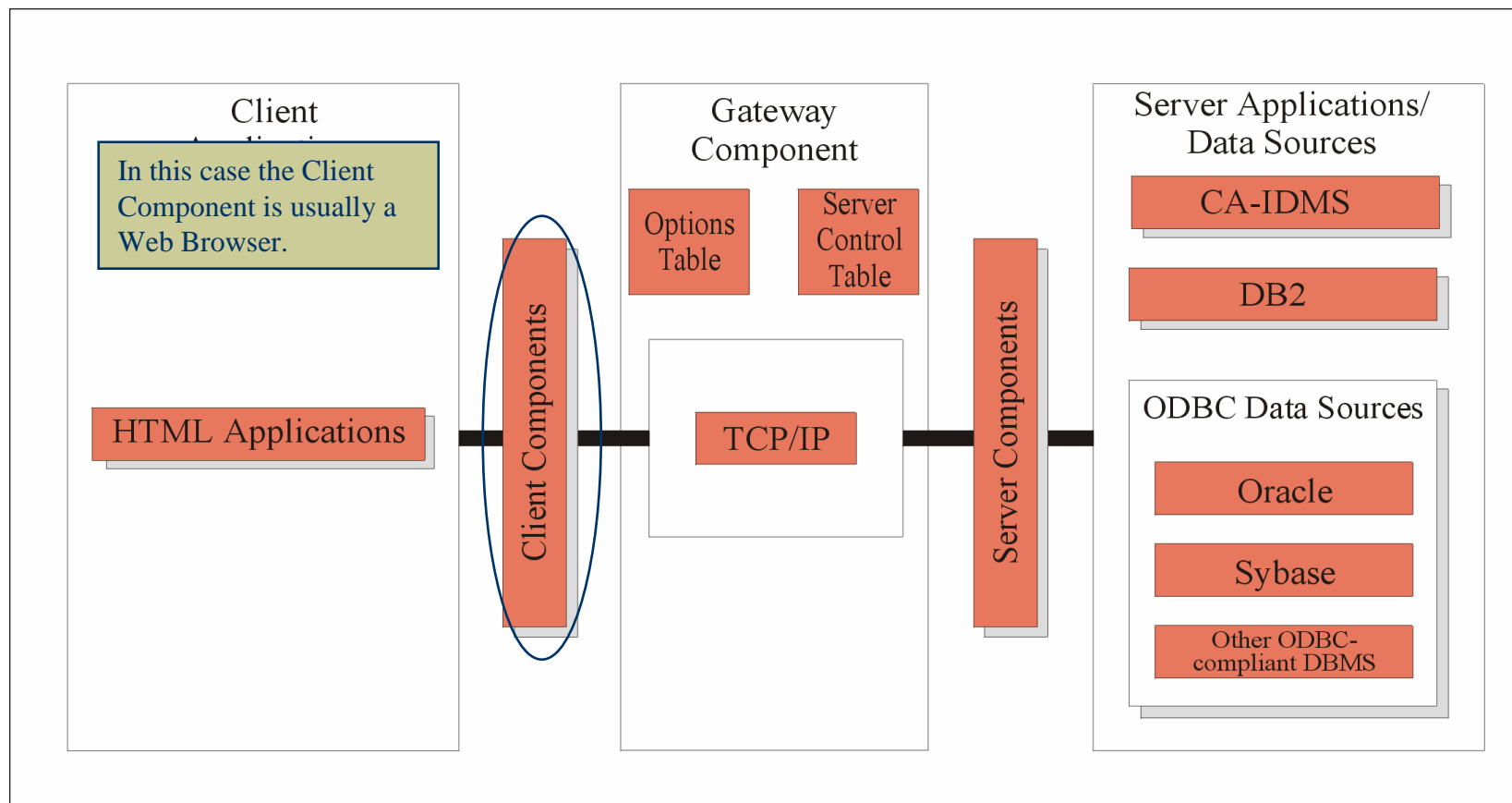

Access CA-IDMS from Internet

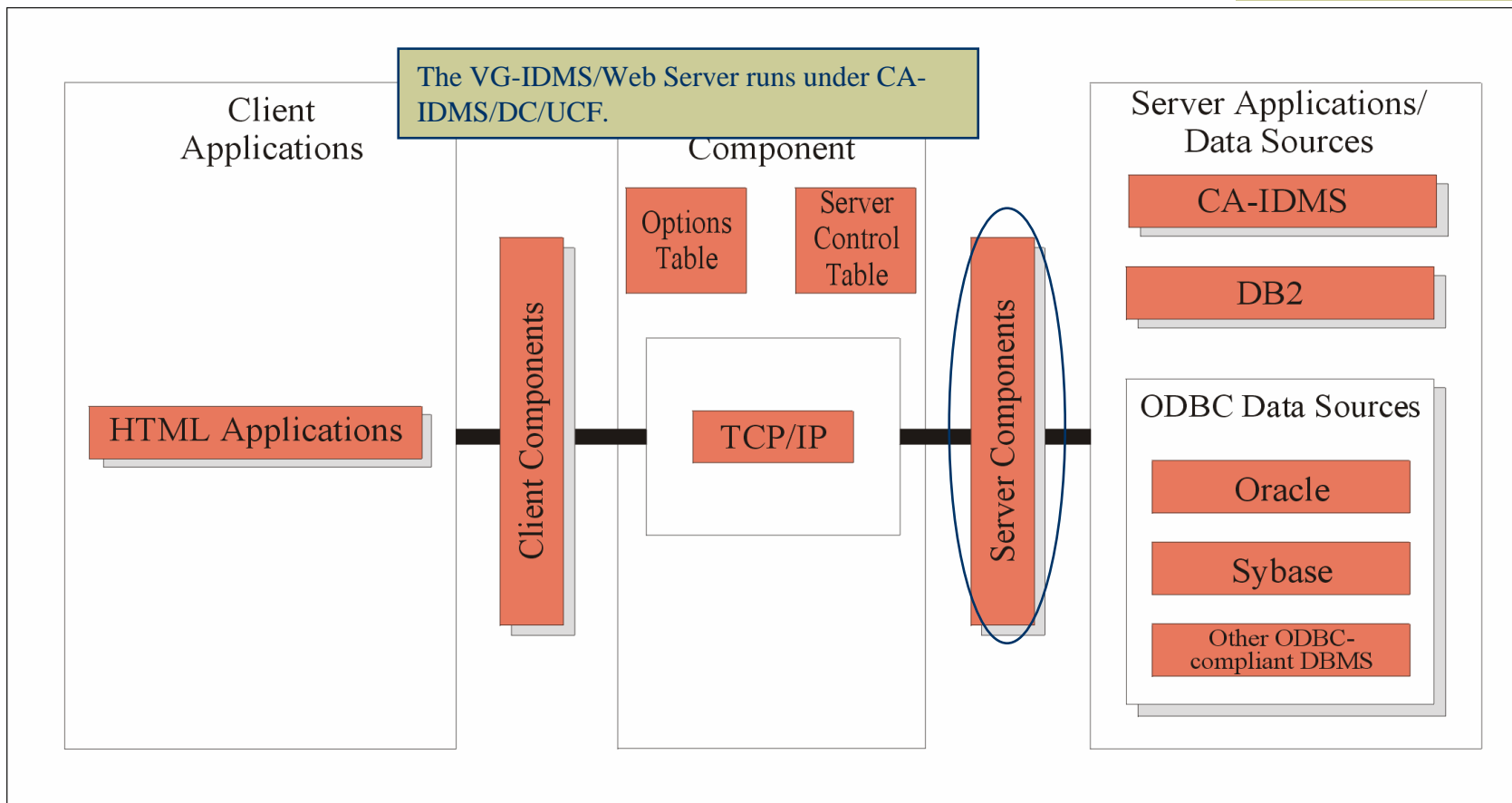

Web Server

- ◆ Web Server does the following:
 - Receives/Sends TCP/IP messages
 - Starts applications based on URL
 - Parses query variables
 - Optionally reads HTML pages from CA-IDD
 - Performs ASCII/EBCDIC conversion
- ◆ HTML text and binary components are supported



Web Server

- ◆ Map Converter included
 - Convert MAPC to HTML
 - Generate code to handle HTML forms
- ◆ SQL Processor included
 - accepts SQL from the Web
 - CA-IDMS/DB (CA-IDMS Server not needed)
 - DB2
 - ODBC

Java Client/Server

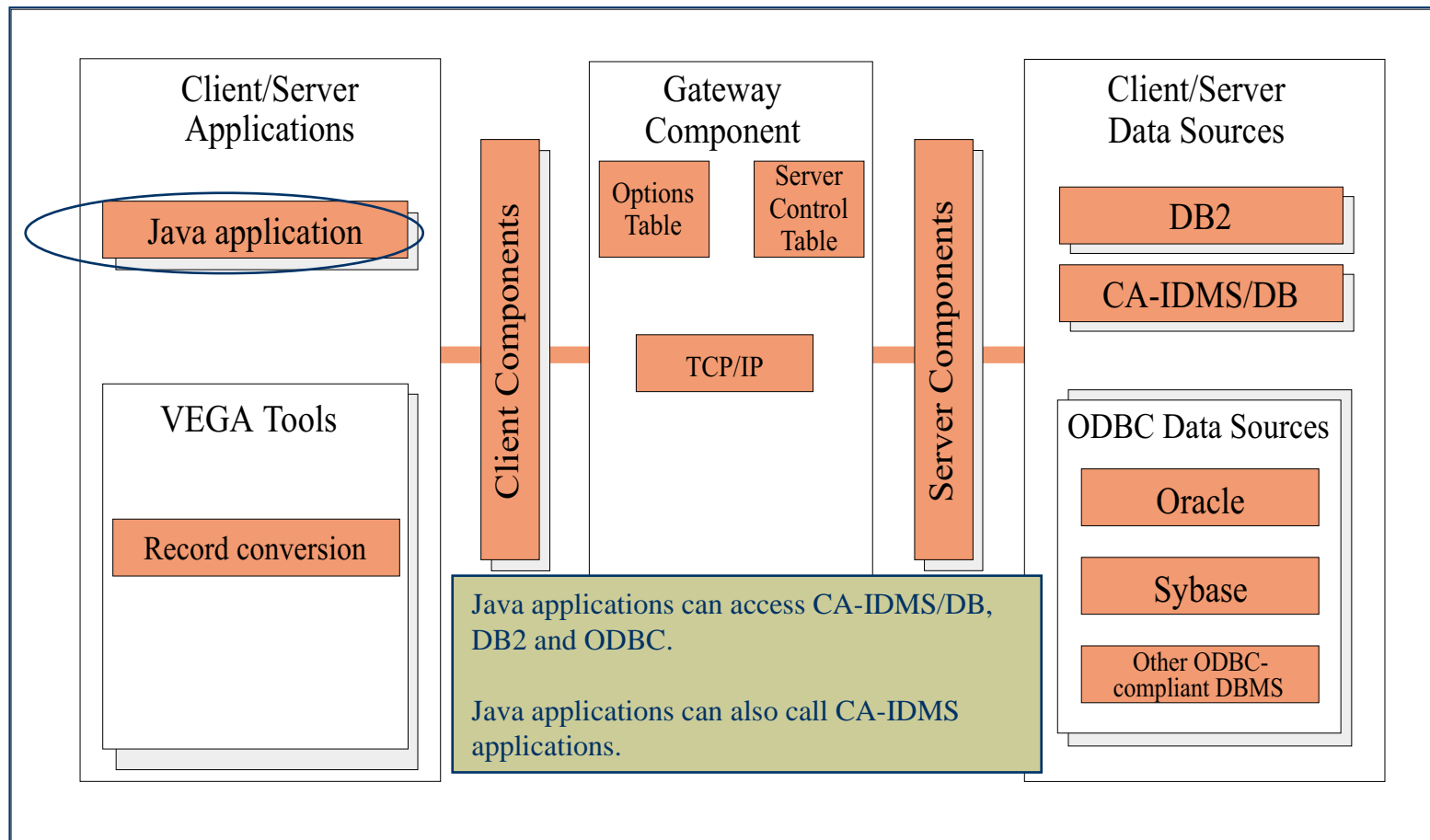

Java Client/Server

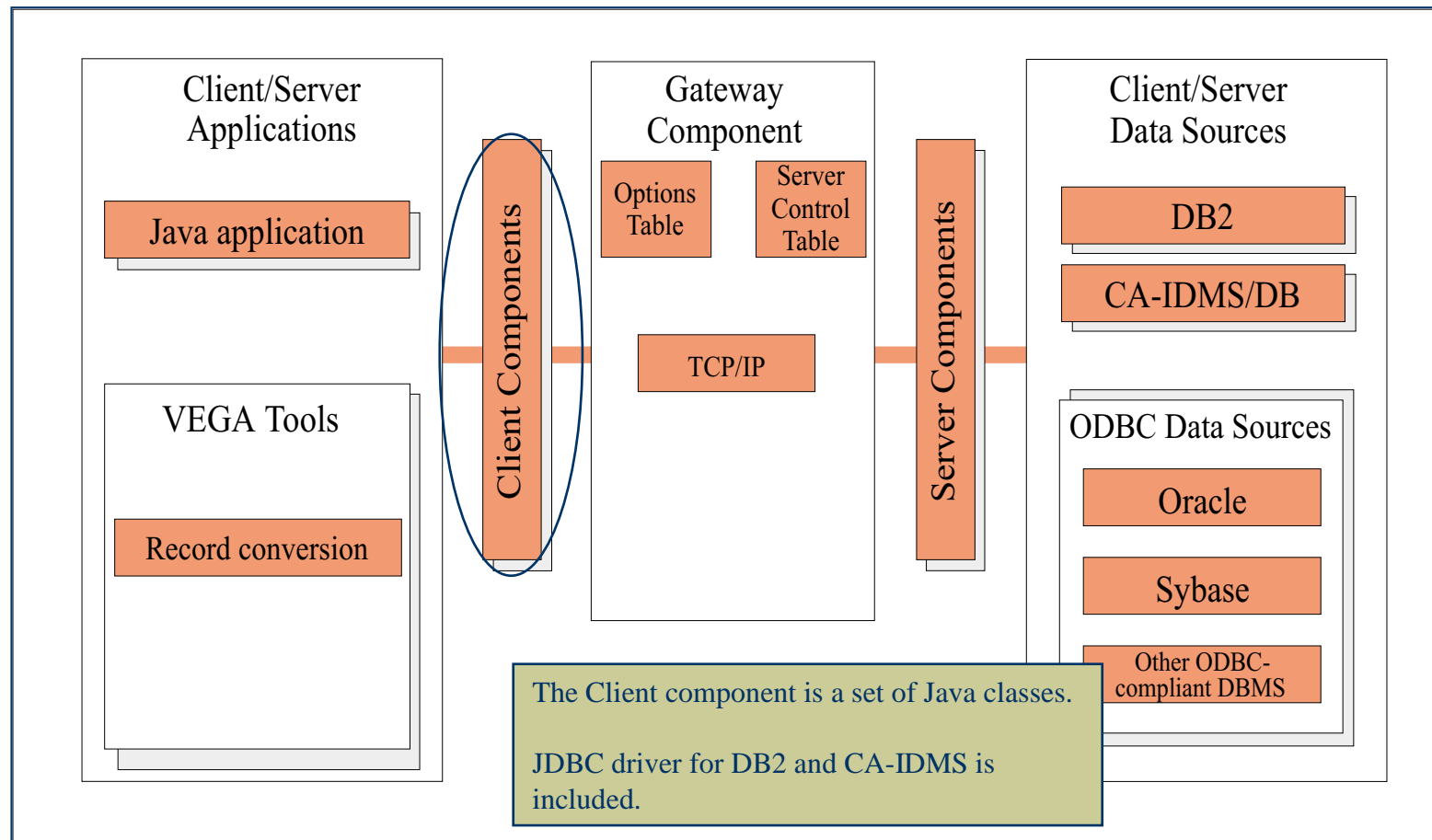

Java Client/Server

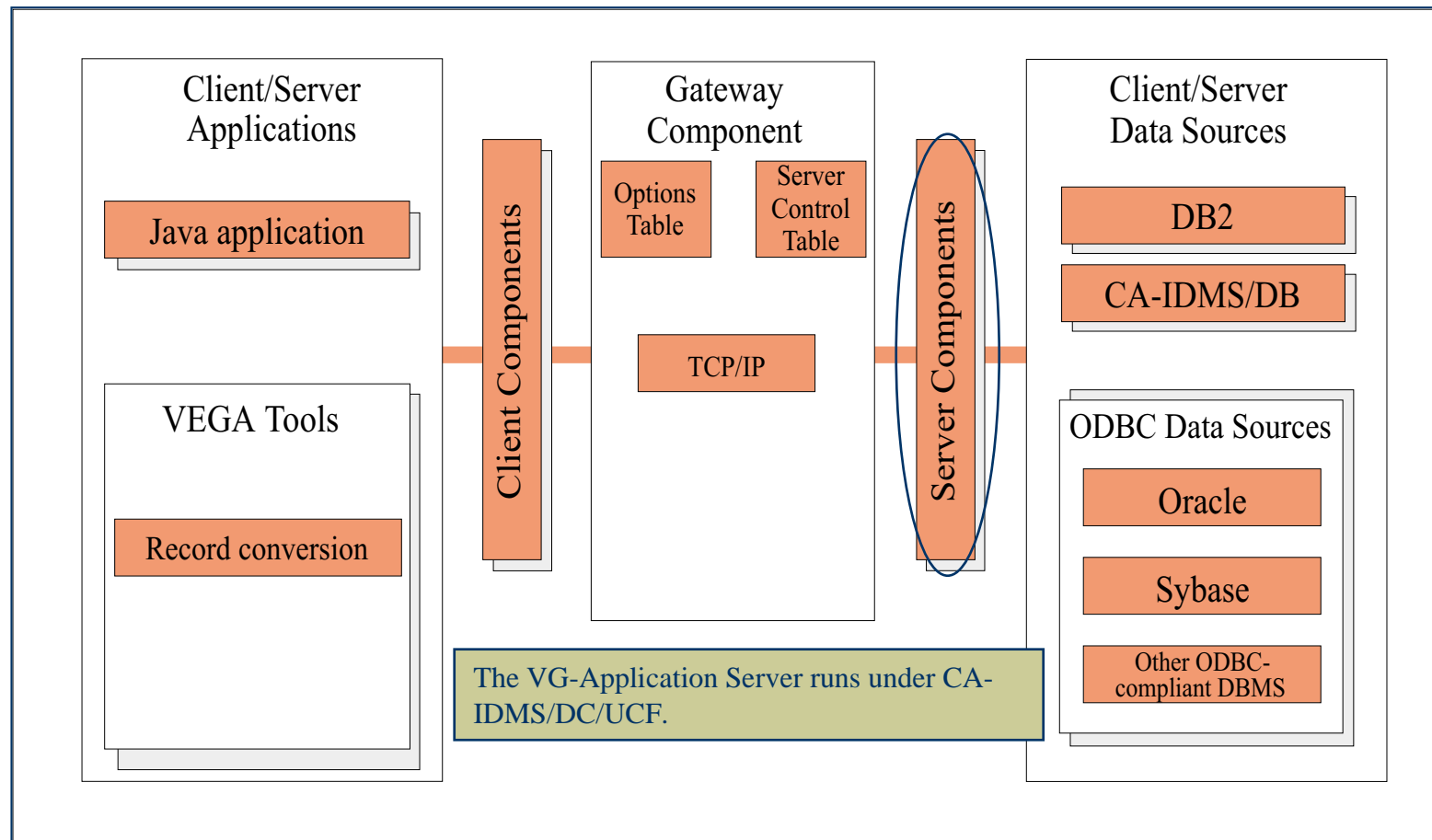

Java Client/Server

- ◆ Any Java application can communicate with VG-Application Server
- ◆ Communication method (TCP/IP) is transparent to applications
- ◆ Client applications can access
 - CA-IDMS/DB via server applications
 - DB2 via server applications
 - DB2 and CA-IDMS/SQL with the included JDBC driver

Java Client/Server

- ◆ Client applications can communicate with
 - CA-IDMS applications
 - Programs
 - Mapless dialogs
- ◆ Tools
 - CA-IDMS Log viewer
 - Binary file upload
 - Java Class generator (from CA-IDD records)
 - DCMT/DCUF command interface

Use TCP/IP in CA-IDMS

- ◆ CICS Sockets compatible API
 - Original Socket API
 - Extended Socket API
- ◆ CA-IDMS/DC is not needed
- ◆ Cross-address space communication based on MVS subtasks
 - no IDMS region waits
- ◆ Listener included (understands HTTP)

Use MQSeries in CA-IDMS

- ◆ MQI compatible API (100%)
- ◆ CA-IDMS/DC is not needed
- ◆ Cross-address space communication based on MVS subtasks
 - no IDMS region waits
- ◆ Trigger monitor included
- ◆ Consistent Update Method
 - synchronizes MQSeries queues and CA-IDMS updates

System Requirements

- ◆ CA-ADS (for VEGA Tools for CA-IDMS)
- ◆ To access DB2:
 - IBM DB2 V2R2 or later
 - CA-IDMS-DC/UCF 10.2x or later
 - optionally CICS/MVS 2.1 or later

System Requirements

- ◆ To access ODBC
 - Server hardware (Intel)
 - Any 32bit Microsoft Windows
 - VG-ODBC Server
 - ODBC-compliant data base system
 - 32bit ODBC driver

System Requirements

- ◆ To access ODBC using TCP/IP
 - VG-IDMS Gateway TCP/IP Option
 - One of the following
 - TCP/IP for MVS
 - OS390 V2R5 or later
 - TCPAccess 4.1 or later
 - Winsock 1.1 or later

System Requirements

- ◆ To access ODBC using APPC (LU6.2)
 - VG-IDMS Gateway Base Option
 - CA-IDMS/DC
 - MS SNA Server 2.11 or later

System Requirements

- ◆ To access VG-Application Server using APPC (LU6.2)
 - VG-IDMS Gateway Base Option
 - VG-Windows Client
 - CA-IDMS/DC
 - MS SNA Server 2.11 or later

System Requirements

- ◆ To access VG-Application Server using TCP/IP
 - VG-IDMS Gateway TCP/IP Option
 - VG-Windows Client or VG-Java Client
 - One of the following
 - TCP/IP for MVS
 - OS390 V2R5 or later
 - CA-NetworkIT TCPAccess 4.1 or later

System Requirements

- ◆ To access CA-IDMS from Internet
 - VG-IDMS Gateway TCP/IP Option
 - One of the following
 - TCP/IP for MVS
 - OS390 V2R5 or later
 - CA-NetworkIT TCPAccess 4.1 or later
 - VG-IDMS/Web Server

System Requirements

- ◆ To use TCP/IP in CA-IDMS
 - VG-IDMS Gateway TCP/IP Option
 - One of the following
 - TCP/IP for MVS
 - OS390 V2R5 or later
 - CA-NetworkIT TCPAccess 4.1 or later



System Requirements



- ◆ To use MQSeries in CA-IDMS
 - VG-IDMS Gateway MQSeries Option
 - IBM MQSeries for MVS